

A. MECHANICAL(UNIT:mm)

RJ45 MECHANICAL NOTES:

REV	ECN NO	DESCRIPTION	DATE
A	/	New Drawing	2025/3/13

- 1.THE PRODUCT IS ROHS COMPLIANT.
- 2.ALL DIMENSIONS FOLLOW :
-FCC SUBPART F, 68,500, FIGURE (C)(2)(I) & (C)(2)(II) & (C)(3)(I) IEC 60603-7
-ALL PLUGS MUST BE MEETING THE REQUIREMENTS OF PLUG GO & NO-GO GAUGE.
- 3.GAUGE FOLLOW : FCC SUBPART F, 68,500, FIGURE (C)(4)(I) & (C)(5)(I)
-THERE MUST BE NO DAMAGE TO HOUSING AND LOCKING LATCH.
-THERE MUST BE NO NICKS AND CUTS IN CABLE.
-DURABILITY : 750 CYCLES GENERALLY
- 4.PART CAN BE RECOMMENDED FOR REFLOW SOLDERING PROCESS.
PEAK REFLOW SOLDERING TEMPERATURE IS 260°C MAX,10SECONDS MAX.
- 5.OPERATING TEMPERATURE:-40 TO +85°C;
- 6.STORAGE TEMPERATURE: -40 TO +85°C

7.MATERIAL:

- 7.1 HOUSING: HIGH TEMPERATURE THERMOPLASTIC LCP,
FLAMMABILITY RATING ,UL 94V-0; COLOR:BLACK.
- 7.2 SHELL: BRASS C2680H, THICKNESS=0.20mm.PLATING NICKEL 30u"Min;
- 7.3 RJ TERMINAL: HIGH TEMPERATURE THERMOPLASTIC LCP,COLOR:BLACK;
UL 94V-0;
PIN:THICKNESS=0.30mm.PHOS-BRONZE C5210EH.
PLATING: 50u" MIN NICKEL UNDERPLATING ALL AREA.
100u" MIN TIN ON SOLDER TAIL.
6u" GOLD ON CONTACT AREA.
- 7.4 INPUT TERMINAL: HIGH TEMPERATURE THERMOPLASTIC LCP COLOR:BLACK;
PHY PIN:THICKNESS=0.30mm. BRASS C2680EH.
LED PIN:THICKNESS=0.45mm. BRASS C2680EH.
PLATING: 50u" MIN NICKEL UNDERPLATING ALL AREA.
100u" MIN TIN ON SOLDER TAIL.
- 7.5 LIGHT PIPE : PC, TRANSPARENT

8.CODING PRINCIPLES

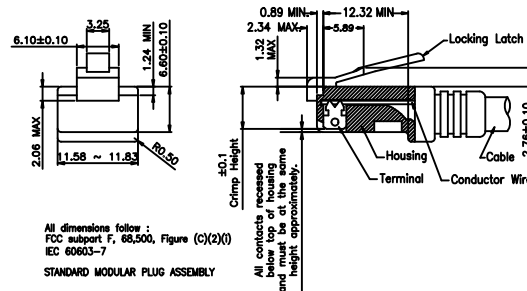
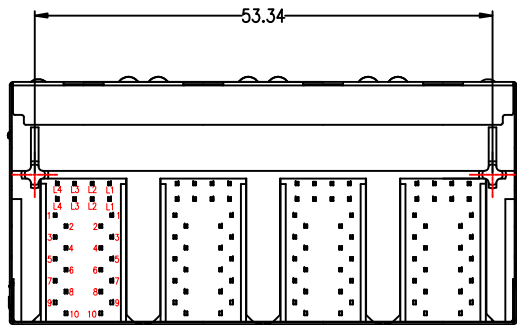
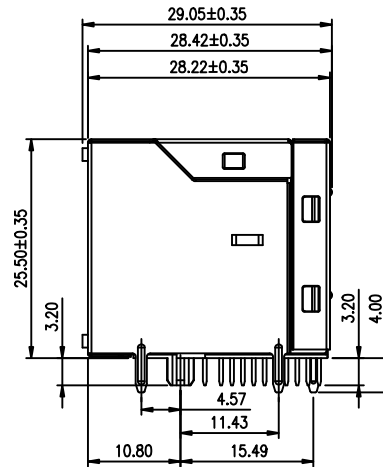
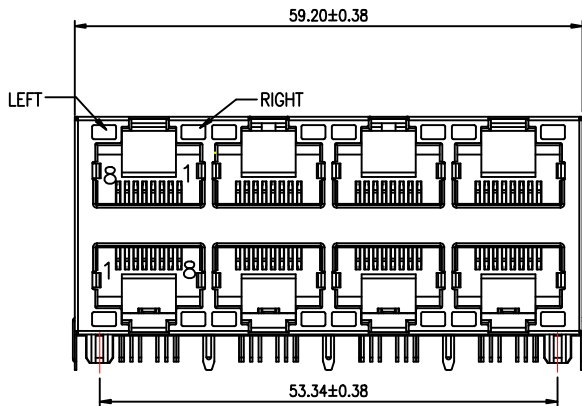
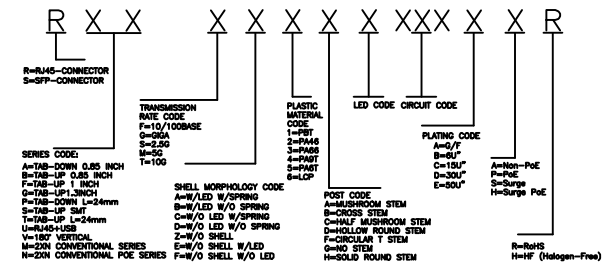

All dimensions follow :
FCC subpart F, 68,500, Figure (C)(2)(I)
IEC 60603-7
STANDARD MODULAR PLUG ASSEMBLY

All contacts recessed
below top of housing
and must be at the same
height approximately.

X. ± 0.40	APPD: LOUIS	深圳市金航标电子有限公司	
.X ± 0.30	CHKD: ZHOU	PART NO: KH-RM4-GB6B5125BAR	
.XX ± 0.25	DR: LIANG	TITLE: 2X4Port 10/100/1000M BASE RJ45 JACK Magnetics	
.XXX ± 0.20	UNITS: mm	SHEET: 1 OF 2	REV: A
X' ± 3'		SCALE: 1:1	DWG NO: RM4-0039
			REMARK: XXX-XXXX



REV	ECN NO	DESCRIPTION	DATE
A	/	New Drawing	2025/3/13

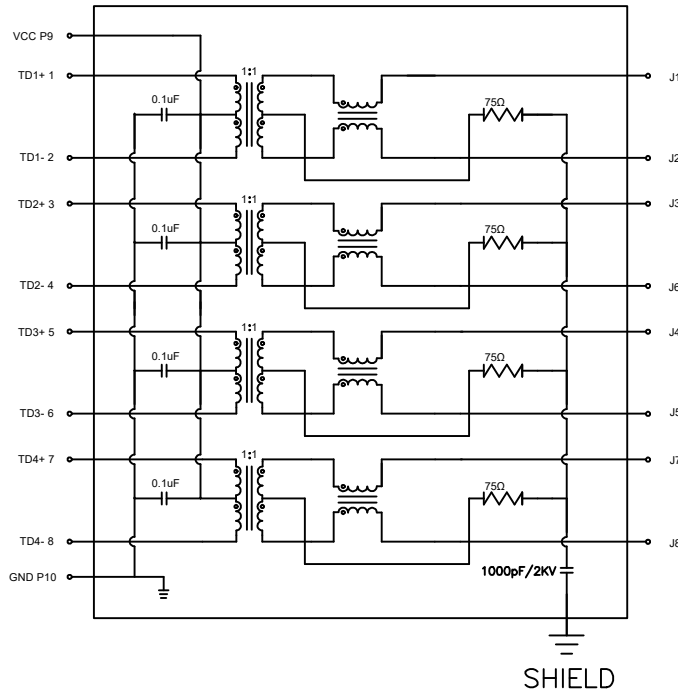

D. ELECTRICAL SPECIFICATIONS @25°C

TRANSMITTER FILTER & RECEIVER FILTER

TYPE : BALANCE LOW PASS 100Ω IMPEDANCE

INSERTION LOSS : 1~120MHz -1.2dB MAX.

RETURN LOSS : 1~30MHz -18dB MIN. LOAD 100Ω
 30~60MHz -16dB MIN. LOAD 100Ω
 60~80MHz -12dB MIN. LOAD 100Ω
 80~100MHz -10dB MIN. LOAD 100Ω

COMMON MODE REJECTION
 @1~100 MHz -30dB MIN.

CROSS TALK
 @ 1~100MHz -30dB MIN.

INDUCTANCE (OCL) @ 100KHz, 0.1V, 8mA DC BIAS 350 uH MIN.

DCR:1.2 OHM MAX

HIPOT TEST
 PHY SIDE(INPUT) TO CABLE SIDE(OUTPUT) : 1500Vrms 60S

C:PIN ASSIGNMENT FOR PCB LAYOUT

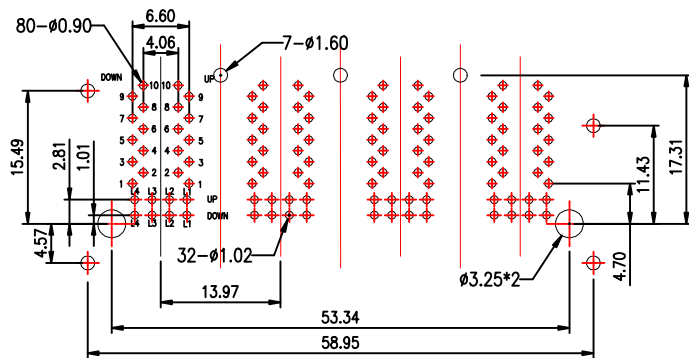

SUGGESTED PCB PAD LAYOUT
 COMPONENT SIDE VIEW

E:LED SPECIFICATION

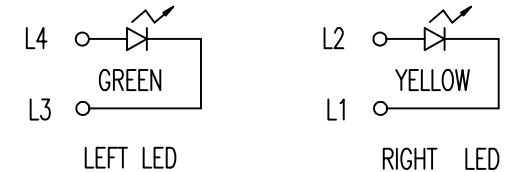

Emitting Color	λp (nm)	Vf @If=20mA	Ir @Vr=5V
GREEN	570	1.7 ~2.6 V	10mA max
YELLOW	590	1.7 ~2.6 V	10mA max

X. ± 0.40	APPD: LOUIS	深圳市金航标电子有限公司	
.X ± 0.30	CHKD: ZHOU		
.XX ± 0.25	DR: LIANG	PART NO: KH-RM4-GB6B5125BAR	TITLE: 2X4Port 10/100/1000M BASE RJ45 JACK Magnetics
.XXX ± 0.20	UNITS: mm	SHEET: 2 OF 2	REV: A
X' ± 3'	.X' ± 2'	SCALE: 1:1	DWG NO: RM4-0039
REMARK: XXX-XXXX		RoHS Compliant	