

REV	ECN NO	DESCRIPTION	DATE
A	/	New Drawing	2025/2/18

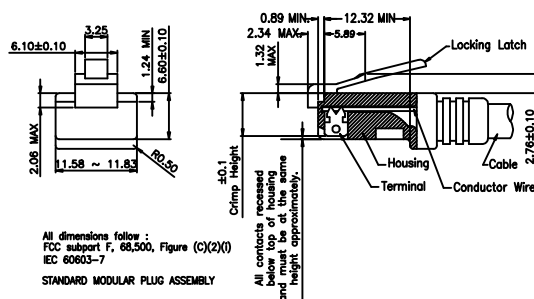
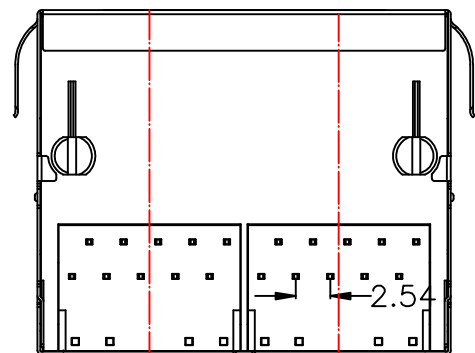
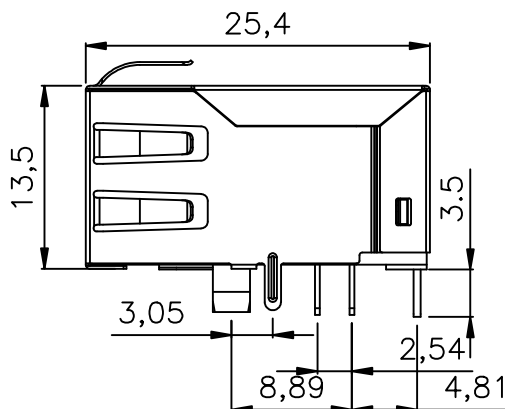
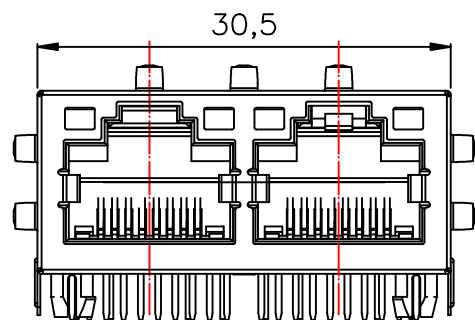

All dimensions follow :  
FCC subpart F, 68,500, Figure (C)(2)(I)  
IEC 60603-7  
STANDARD MODULAR PLUG ASSEMBLY

- 1.THE PRODUCT IS ROHS COMPLIANT.
- 2.ALL DIMENSIONS FOLLOW :  
-FCC SUBPART F, 68,500, FIGURE (C)(2)(I) & (C)(2)(II) & (C)(3)(I) IEC 60603-7  
-ALL PLUGS MUST BE MEETING THE REQUIREMENTS OF PLUG GO & NO-GO GAUGE.
- 3.GAUGE FOLLOW : FCC SUBPART F, 68,500, FIGURE (C)(4)(I) & (C)(5)(I)  
-THERE MUST BE NO DAMAGE TO HOUSING AND LOCKING LATCH.  
-THERE MUST BE NO NICKS AND CUTS IN CABLE.  
-DURABILITY : 750 CYCLES GENERALLY
- 4.PART CAN BE RECOMMENED FOR REFLOW SOLDERING PROCESS.  
PEAK REFLOW SOLDERING TEMPERATURE IS 260°C MAX,10SECONDS MAX.
- 5.OPERATING TEMPERATURE:-40 TO +85°C;
- 6.STORAGE TEMPERATURE: -40 TO +85°C

7.MATERIAL:

- 7.1 HOUSING: THERMOPLASTIC PBT.  
FLAMMABILITY RATING ,UL 94V-0; COLOR:BLACK.
- 7.2 SHELL: BRASS C2680H, THICKNESS=0.20mm.PLATING NICKEL 30u"Min;
- 7.3 RJ TERMINAL: THERMOPLASTIC PBT,COLOR:BLACK;UL 94V-0;  
PIN:THICKNESS=0.30mm.PHOS-BRONZE C5210EH.  
PLATING: 50u" MIN NICKEL UNDERPLATING ALL AREA.  
100u" MIN TIN ON SOLDER TAIL.  
6u" GOLD ON CONTACT AREA.
- 7.4 INPUT TERMINAL: PHY PIN:THICKNESS=0.30mm. BRASS C2680H.  
LED PIN:THICKNESS=0.45mm. BRASS C2680H.  
PLATING: 50u" MIN NICKEL UNDERPLATING ALL AREA.  
100u" MIN TIN ON SOLDER TAIL.

8.CODING PRINCIPLES

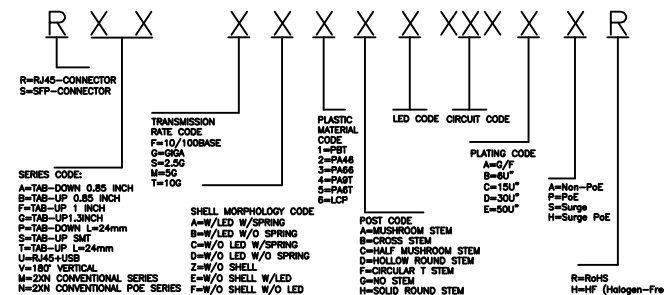

X. ± 0.40	APPD: LOUIS	深圳市金航标电子有限公司	
.X ± 0.30	CHKD: ZHOU	PART NO: KH-RF2-GA1A2117BAR	
.XX ± 0.25	DR: LIANG	TITLE: TAB UP 1X2Port 10/100/1000M BASE-T RJ45 JACK Magnetics	
.XXX ± 0.20	UNITS: mm	SHEET: 1 OF 2	REMARK: XXX-XXXX
X' ± 3'	.X' ± 2'	SCALE: 1:1	REMARK: XXX-XXXX
UNITS: mm	SCALE: 1:1	REV: A	DWG NO: RF2-0007
UNITS: mm	SCALE: 1:1	REV: A	DWG NO: RF2-0007



REV	ECN NO	DESCRIPTION	DATE
A	/	New Drawing	2025/2/18

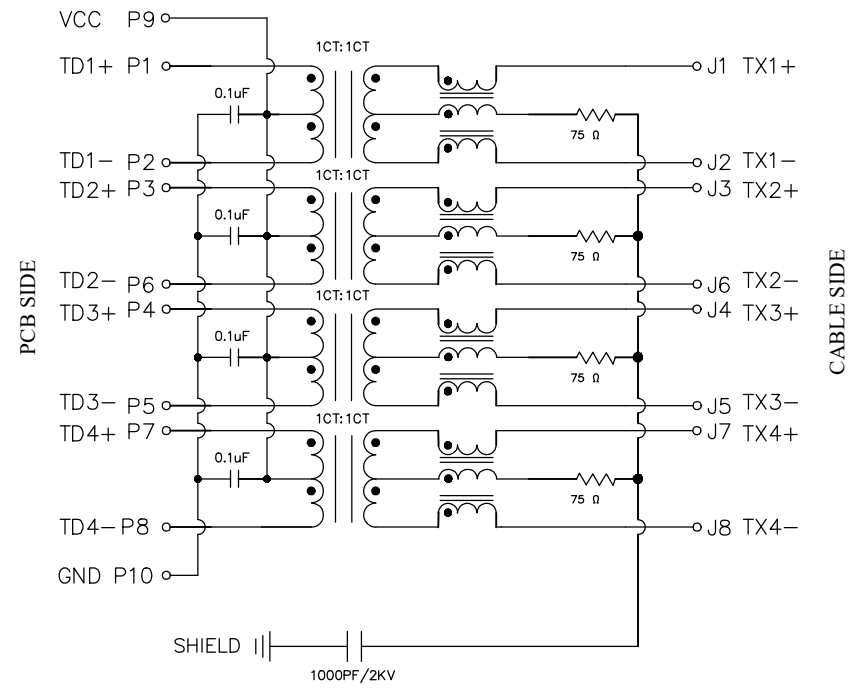

D. ELECTRICAL SPECIFICATIONS @25°C

TRANSMITTER FILTER & RECEIVER FILTER

TYPE : BALANCE LOW PASS 100Ω IMPEDANCE

INSERTION LOSS : 1~120MHz -1.2dB MAX.

RETURN LOSS : 1~30MHz -18dB MIN. LOAD 100Ω  
 30~60MHz -16dB MIN. LOAD 100Ω  
 60~80MHz -12dB MIN. LOAD 100Ω  
 80~100MHz -10dB MIN. LOAD 100Ω

COMMON MODE REJECTION  
 @1~100 MHz -30dB MIN.

CROSS TALK  
 @ 1~100MHz -30dB MIN.

INDUCTANCE (OCL) @ 100KHz, 0.1V, 8mA DC BIAS 350 uH MIN.

DCR:1.2 OHM MAX

HIPOT TEST  
 PHY SIDE(INPUT) TO CABLE SIDE(OUTPUT) : 1500Vrms 60S

C:PIN ASSIGNMENT FOR PCB LAYOUT

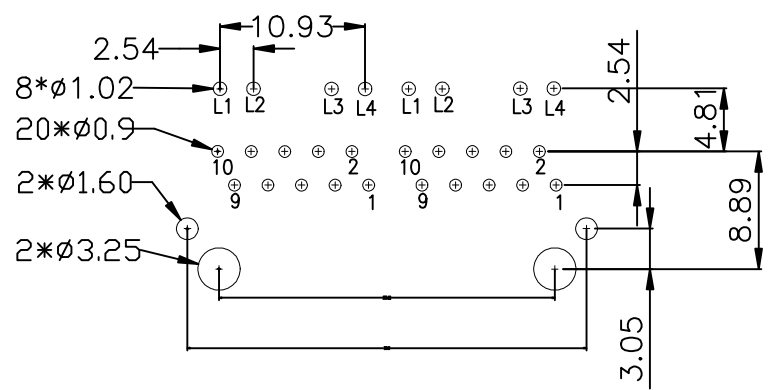

SUGGESTED PCB PAD LAYOUT  
 COMPONENT SIDE VIEW

E:LED SPECIFICATION

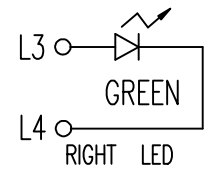
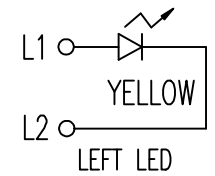

Emitting Color	λp (nm)	Vf @If=20mA	Ir @Vr=5V
GREEN	570	1.7 ~2.6 V	10mA max
YELLOW	590	1.7 ~2.6 V	10mA max

X. ± 0.40	APPD: LOUIS	深圳市金航标电子有限公司	
.X ± 0.30	CHKD: ZHOU	PART NO: KH-RF2-GA1A2117BAR	
.XX ± 0.25	DR: LIANG	TITLE: TAB UP 1X2Port 10/100/1000M BASE-T RJ45 JACK Magnetics	
.XXX ± 0.20	UNITS: mm	SHEET: 2 OF 2	
X' ± 3'		REV: A	DWG NO: RF2-0007
		SCALE: 1:1	REMARK: XXX-XXXX

